

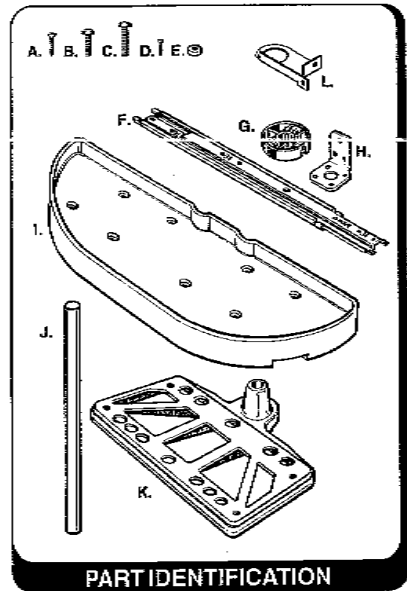

31" HALF MOON (BLIND CORNER) INSTRUCTIONS (Right Side Illustration Only)

IMPORTANT: Before you begin, familiarize yourself with the kit contents, identify all parts, read through all instruction information and have the necessary tools on hand to get started.

CUSTOMER SERVICE: Toll Free Consumer Help Line for your product questions during the weekday business hours:
800-626-1126



- | | |
|--|----------|
| A. #8 x 3/4" Oval Head Phillips Wood Screw | -7 req. |
| B. 1/4 - 20 x 3/4" Phillips Machine Screw | -4 req. |
| C. 1/4 - 20 x 1" Phillips Machine Screw | -8 req. |
| D. #10 x 1/2" Phillips Machine Screw | -4 req. |
| E. Plastic Screw Hole Caps | -16 req. |
| F. Slide Assembly | -2 req. |
| G. Positioner Base Assembly | -2 req. |
| H. Support Bracket | -1 req. |
| I. Half Moon Tray | -2 req. |
| J. Shaft 17" w/cap | -1 req. |
| K. Shelf Support | -2 req. |
| L. Rev-A-Tray Support Bracket | -1 req. |

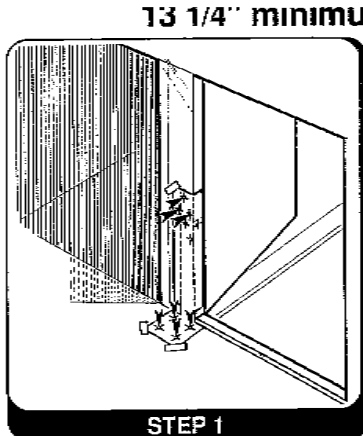

STEP 1
Position and tape template on inside of the face frame vertically (hinge side) as shown in illustration. Using a 1/16" diameter bit, drill 5/8" deep pilot holes through the template at the 7 arrow locations shown. **NOTE:** If installing Rev-A-Tray (single tray) note hole locations on template.

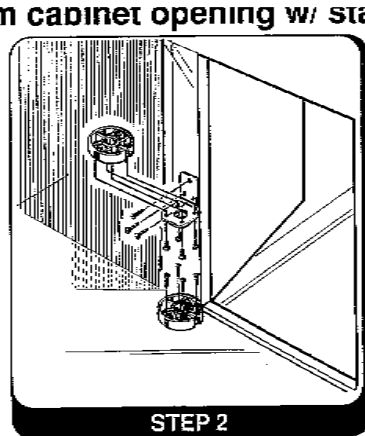

STEP 2
Match positioner base over 4 base holes as shown and install to cabinet bottom using four (4) #8 x 3/4" oval head Phillips wood screws. Match support bracket over 3 remaining pilot holes as shown and install it to cabinet frame using three (3) #8 x 3/4" oval head Phillips wood screws. Now match the other positioner base over the 4 support bracket four (4) #10 x 1/2" machine screws. **NOTE:** Lock down screw on positioner base assembly toward opening. **NOTE:** For Rev-A-Tray use bracket (L).

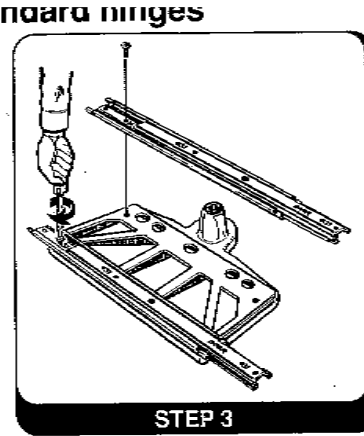

STEP 3
Place slides on top of shelf support with "this side toward door opening" so it will be closest to door opening. Pull top half of slide all the way out and match bottom half "31" (as shown) over threaded holes of the shelf support and fasten to shelf support using two (2) 1/4 - 20 x 3/4" Phillips machine screws.

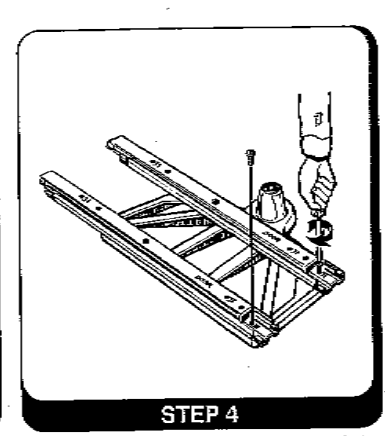

STEP 4
Move top half of slides back until you see "31" holes on bottom half of each slide. Match "31" holes over threaded shelf support holes and fasten this end of each slide bottom to the shelf support using two (2) more 1/4 - 20 x 3/4" Phillips machine screws.

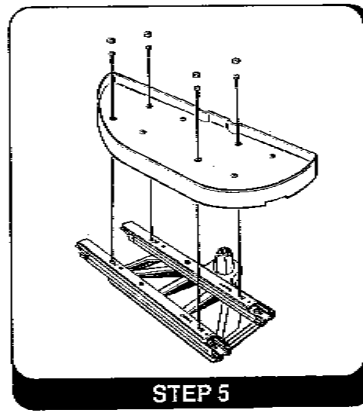

STEP 5
Now match tray over the slide rails with the 4 holes shown matched over the 4 "31" on the top half of the slide rails. Fasten tray to rails using four (4) 1/4 - 20 x 1" Phillips machine screws. Then push plastic caps into all 8 tray holes (illustration shows 4 in place and 4 above screws).

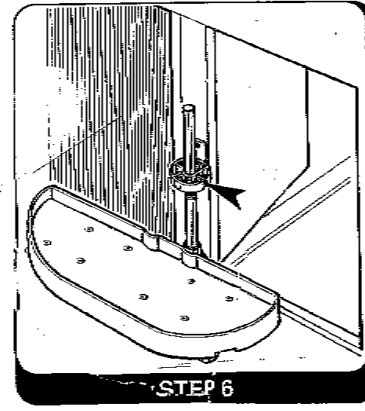

STEP 6
Take your pivot & slide assembly, match it over the bottom positioner base and insert the shaft through the top positioner base, the pivot and slide assembly, and into the bottom positioner base until shaft bottom (open end) sets on cabinet bottom. Now using your screw driver, tighten the set screws on both positioner bases (arrow top set screw). Be sure to tighten bottom positioner base set screw (not visible in illustration).

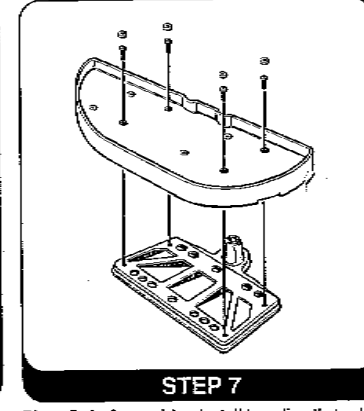

STEP 7
Pivot Only Assembly: Install tray directly to shelf support using four (4) 1/4 - 20 x 1" Phillips machine screws. **Note:** Make sure screws are installed through the tray at the 4 locations shown in the illustration.

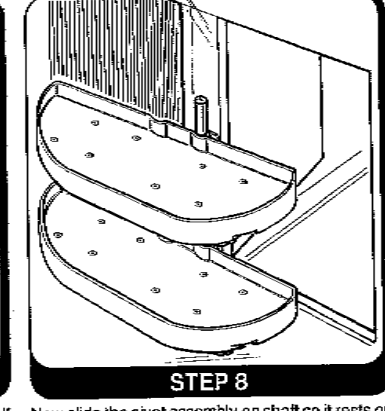

STEP 8
Now slide the pivot assembly on shaft so it rests on the top positioner base. Your installation is now complete and should look like the illustration.

REV-A-SHELF®
Your Total Accessory Source!

P.O. Box 99585 • Jeffersonton, KY 40299
800-626-1126 • FAX 502-491-2215

1-6860-31



31" HALF MOON (BLIND CORNER) INSTRUCTIONS (Left Side Illustration Only)

IMPORTANT: Before you begin, familiarize yourself with the kit contents, identify all parts, read through all instruction information and have the necessary tools on hand to get started.

CUSTOMER SERVICE: Toll Free Consumer Help Line for your product questions during the weekday business hours:
800-626-1126

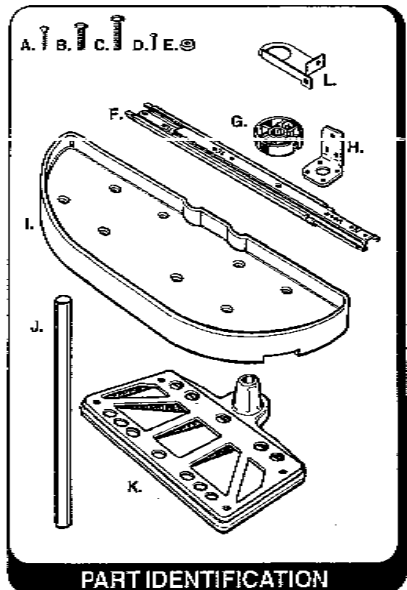

- | | |
|---|----------|
| A. #8 x 3/4" Oval Head Phillips Wood Screws | -7 req. |
| B. 1/4 - 20 x 3/4" Phillips Machine Screws | -4 req. |
| C. 1/4 - 20 x 1" Phillips Machine Screws | -8 req. |
| D. #10 x 1/2" Phillips Machine Screws | -4 req. |
| E. Plastic Screw Hole Caps | -16 req. |
| F. Slide Assembly | -2 req. |
| G. Positioner Base Assembly | -2 req. |
| H. Support Bracket | -1 req. |
| I. Half Moon Tray | -2 req. |
| J. Shaft 17" w/cap | -1 req. |
| K. Shelf Support | -2 req. |
| L. Rev-A-Tray Support Bracket | -1 req. |

13 1/4" minimum cabinet opening w/ standard hinges

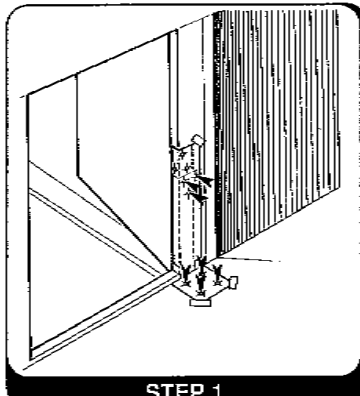

STEP 1
Position and tape template on inside of the face frame vertically (hinge side) as shown in illustration. Using a 1/16" diameter bit, drill 5/8" deep pilot holes through the template at the 7 arrow locations shown. **NOTE:** If installing Rev-A-Tray (single tray) note hole locations on template.

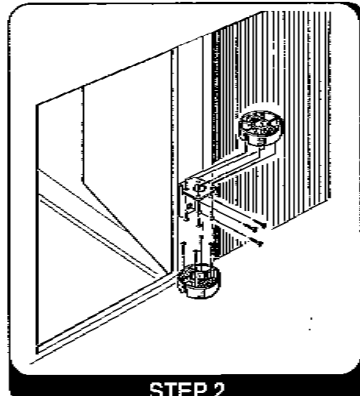

STEP 2
Match positioner base over 4 base holes as shown and install to cabinet bottom using four (4) #8 x 3/4" oval head Phillips wood screws. Match support bracket over 3 remaining pilot holes as shown and install it to cabinet frame using three (3) #8 x 3/4" oval head Phillips wood screws. Now match the other positioner base over the 4 support bracket four (4) #10 x 1/2" machine screws **NOTE:** Lock down screw on positioner base assembly toward opening. **NOTE:** For Rev-A-Tray use bracket (L).

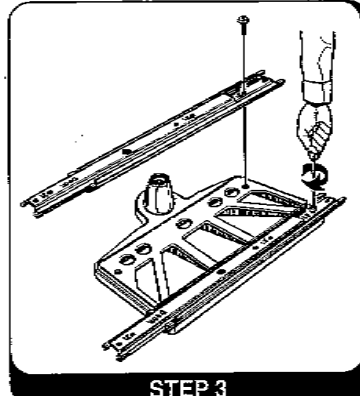

STEP 3
Place slides on top of shelf support with "this side toward door opening" so it will be closest to door opening. Pull top half of slide all the way out and match bottom half "31" (as shown) over threaded holes of the shelf support and fasten to shelf support using two (2) (1 per slide) 1/4 - 20 x 3/4" Phillips machine screws.

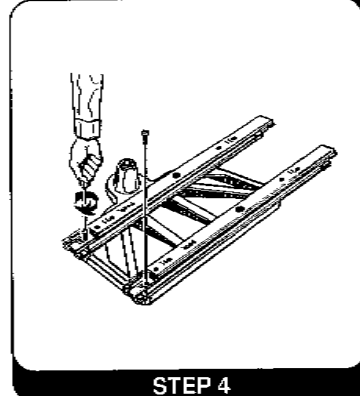

STEP 4
Move top half of slides back until you see "31" holes on bottom half of each slide. Match "31" holes over threaded shelf support holes and fasten this end of each slide bottom to the shelf support using two (2) more 1/4 - 20 x 3/4" Phillips machine screws.

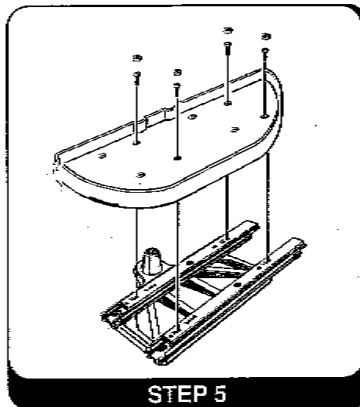

STEP 5
Now match tray over the slide rails with the 4 holes shown matched over the 4 "31"s on the top half of the slide rails. Fasten tray to rails using four (4) 1/4 - 20 x 1" Phillips machine screws. Then push plastic caps into all 8 tray holes (illustration shows 4 in place and 4 above screws).

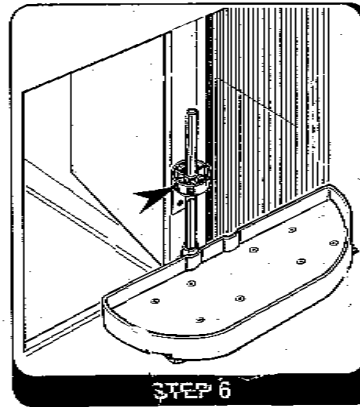

STEP 6
Take your pivot & slide assembly, match it over the bottom positioner base and insert the shaft through the top positioner base, the pivot and slide assembly, and into the bottom positioner base until shaft bottom (open end) sets on cabinet bottom. Now using your screw driver, tighten the set screws on both positioner bases (arrow top set screw). Be sure to tighten bottom positioner base set screw (not visible in illustration).

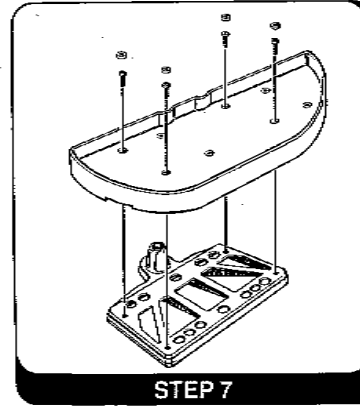

STEP 7
Pivot Only Assembly: Install tray directly to shelf support using four (4) 1/4 - 20 x 1" Phillips machine screws. **Note:** Make sure screws are installed through the tray at the 4 locations shown in the illustration.

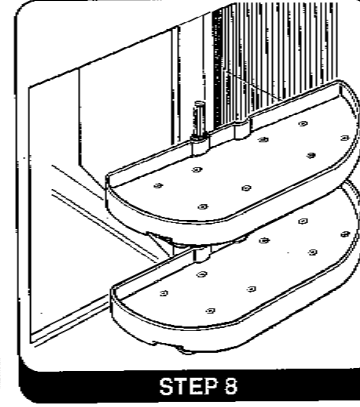

STEP 8
Now slide the pivot assembly on shaft so it rests on the top positioner base. Your installation is now complete and should look like the illustration.



P.O. Box 99585 • Jeffersonton, KY 40298
800-626-1126 • FAX 502-491-2215

1-6600-31